



Increased Serial NOR Performance Enables New Applications

Cliff Zitlaw
Spancion
Session 303E

History

SPI

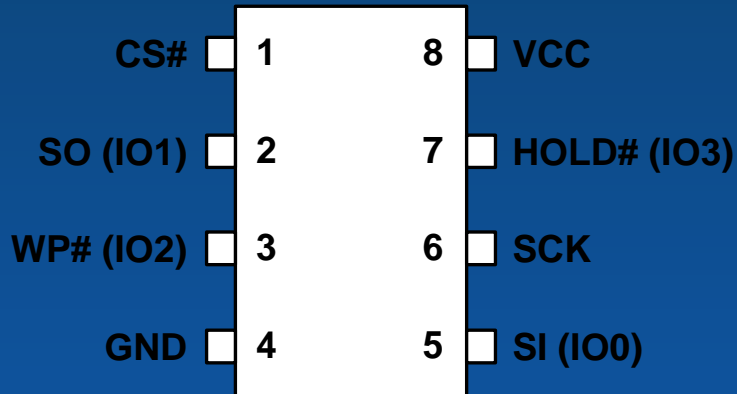

MicroWire

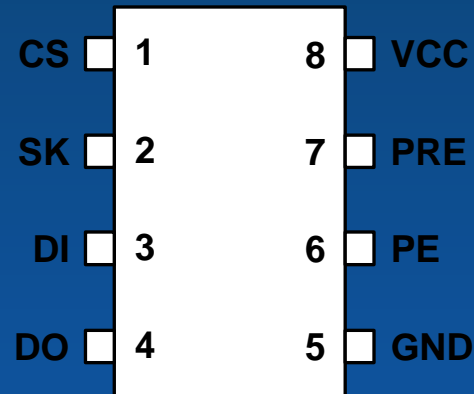

I²C

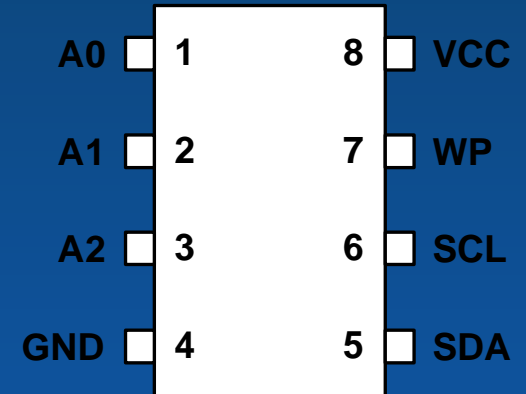

Bus Width Expansion

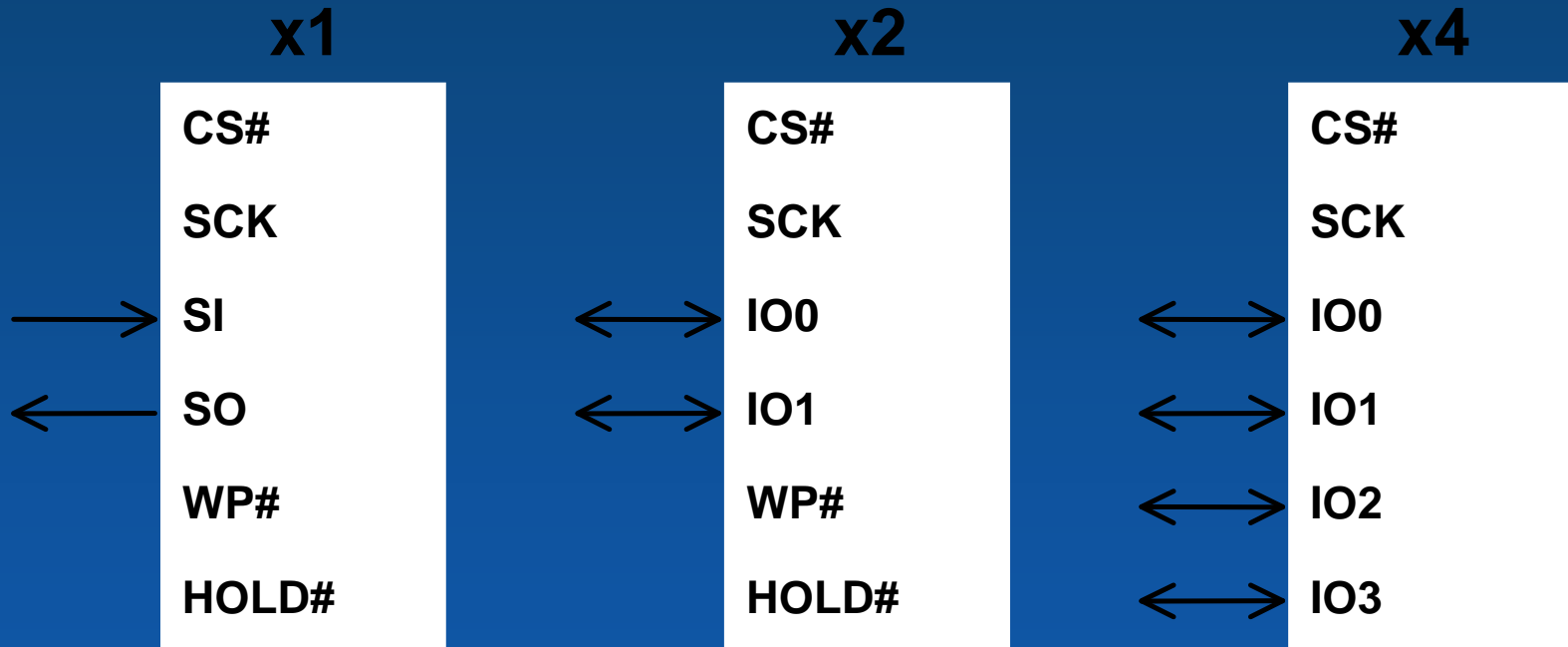

Pin/Performance Comparison

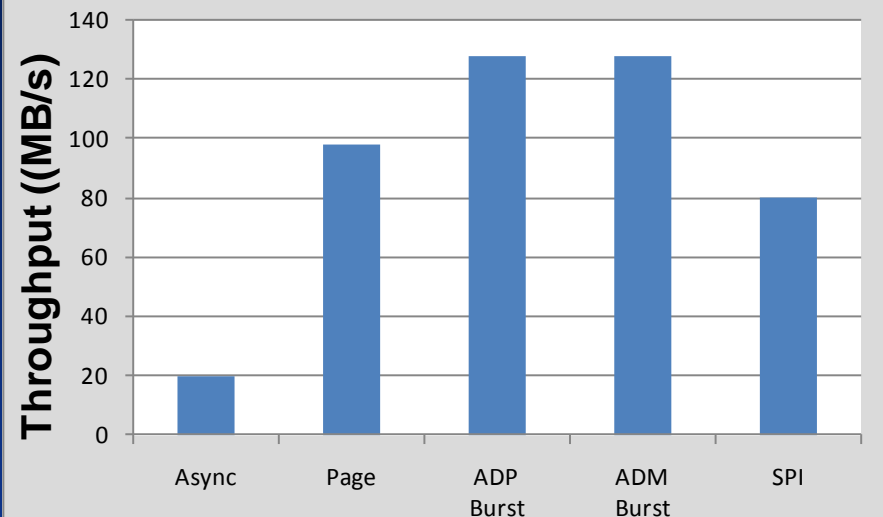
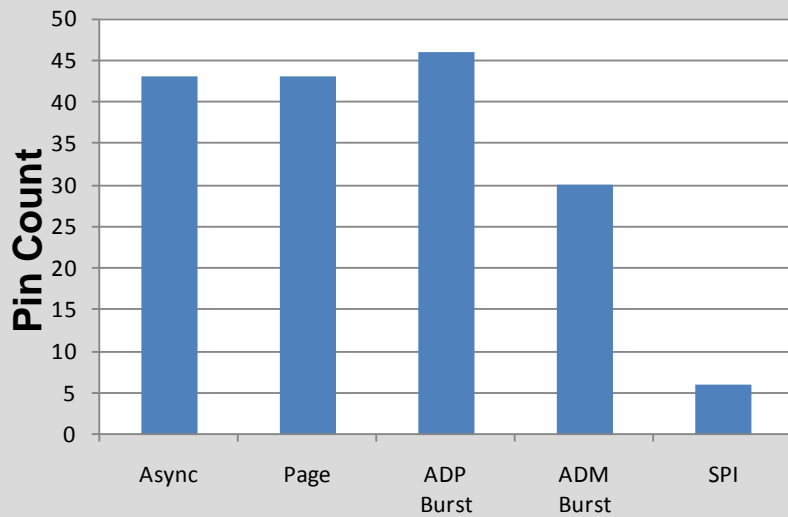

Direct CPU Memory Mapping

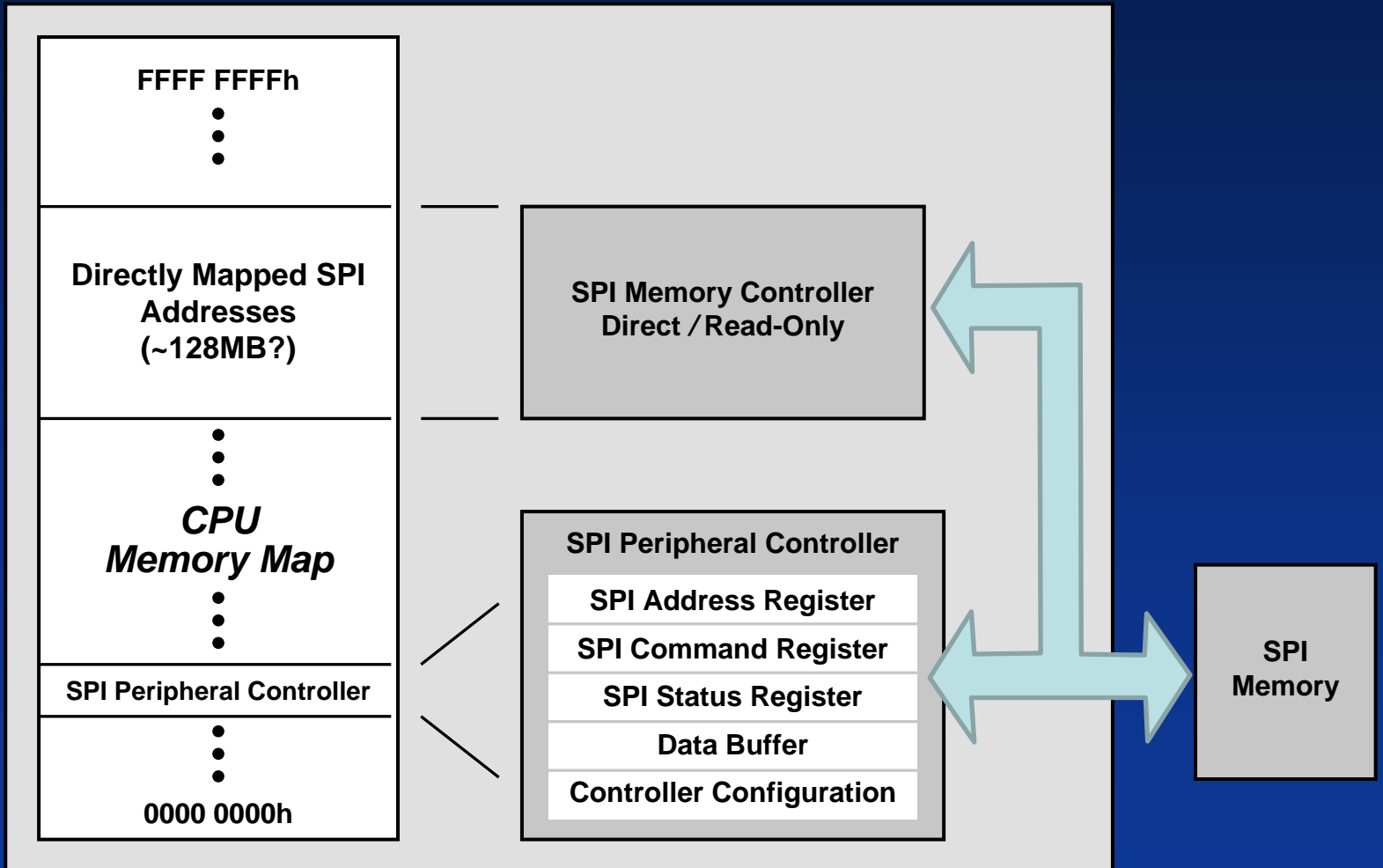

Quad Output Read

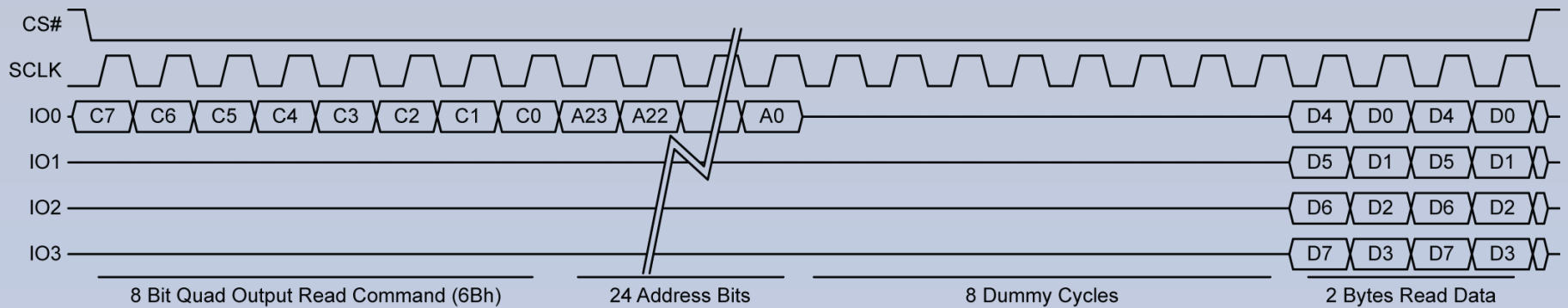



Quad IO-DDR with Data Learning Pattern

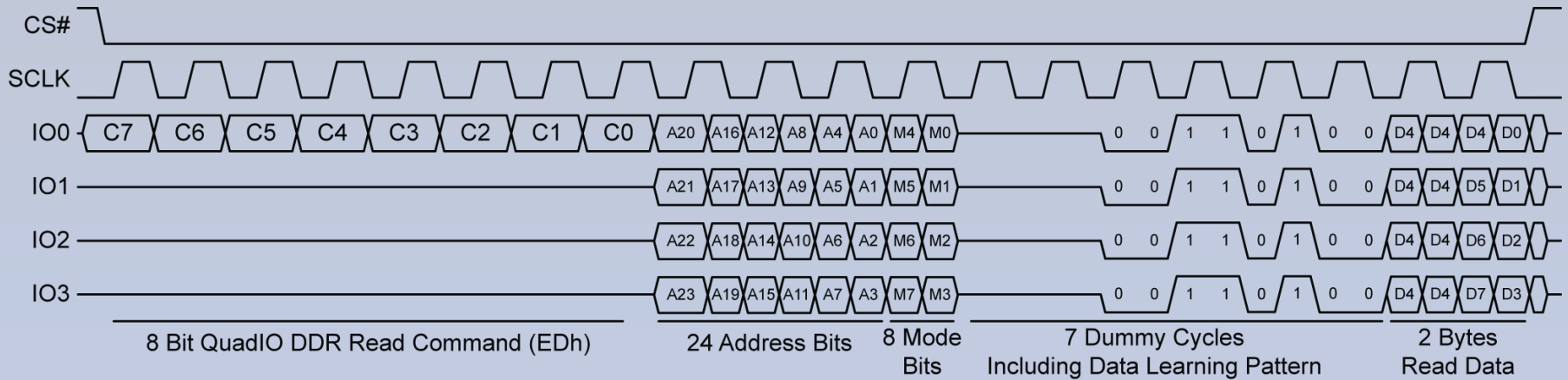

Quad IO-DDR + DLP + Command Elimination

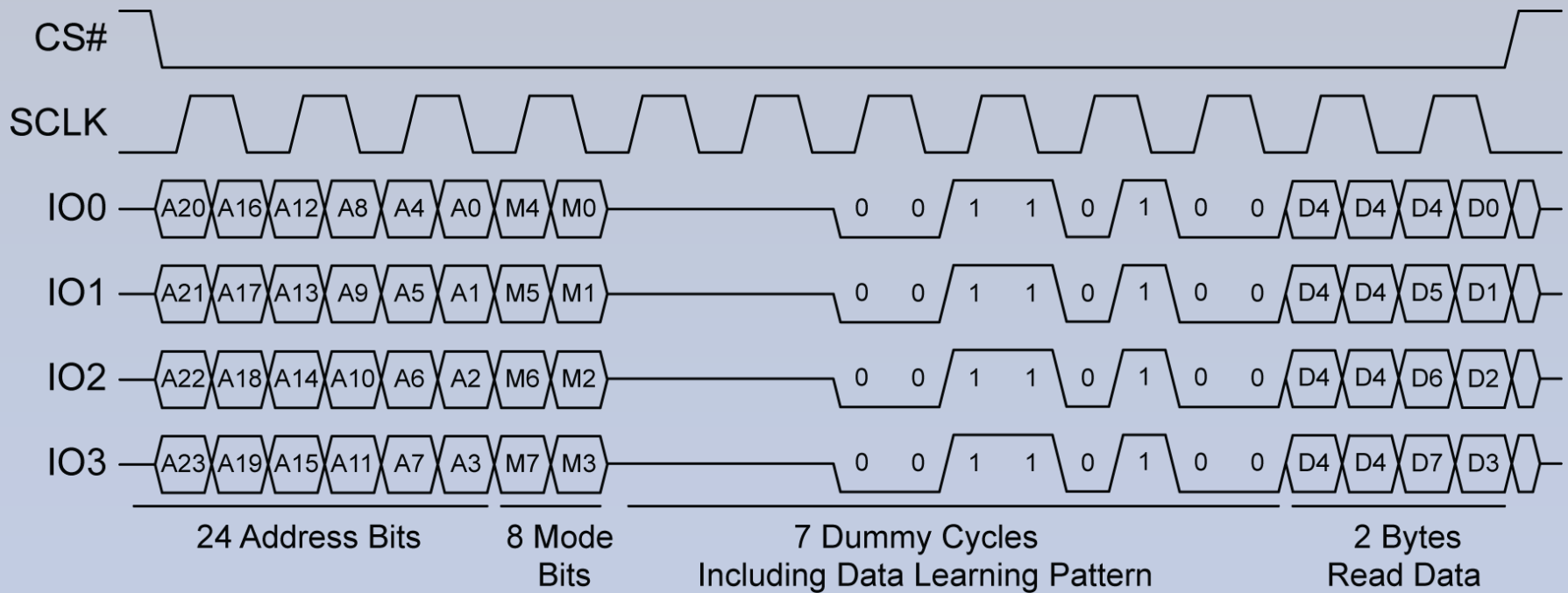

The Future

- Higher Read Performance
 - DDR to become more widely accepted
 - Need for a data strobe
 - x8 data bus?
- JEDEC Standardization?
 - Serial Flash Discoverable Parameters (SFDP)
- Another 25 Years