

# Finding Flash Features: bigger, better, faster... stronger ECC

Laura M. Grupp<sup>\*</sup>, Hung-Wei Tseng<sup>\*</sup>, Adrian M. Caulfield<sup>\*</sup>, Joel Coburn<sup>\*</sup>,  
Eitan Yaakobi<sup>†</sup>, Paul H. Siegel<sup>†</sup>, Jack K. Wolf<sup>†</sup>, Steven Swanson<sup>\*</sup>

<sup>\*</sup>Non-volatile Systems Laboratory, Department of Computer Science and Engineering

<sup>†</sup>Center for Magnetic Recording Research

Jacob's School of Engineering

University of California, San Diego

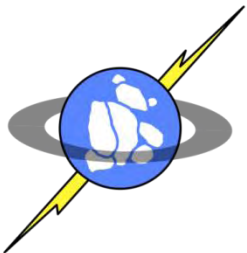

UCSD CSE  
Computer Science and Engineering



# Ultimate Goal

---

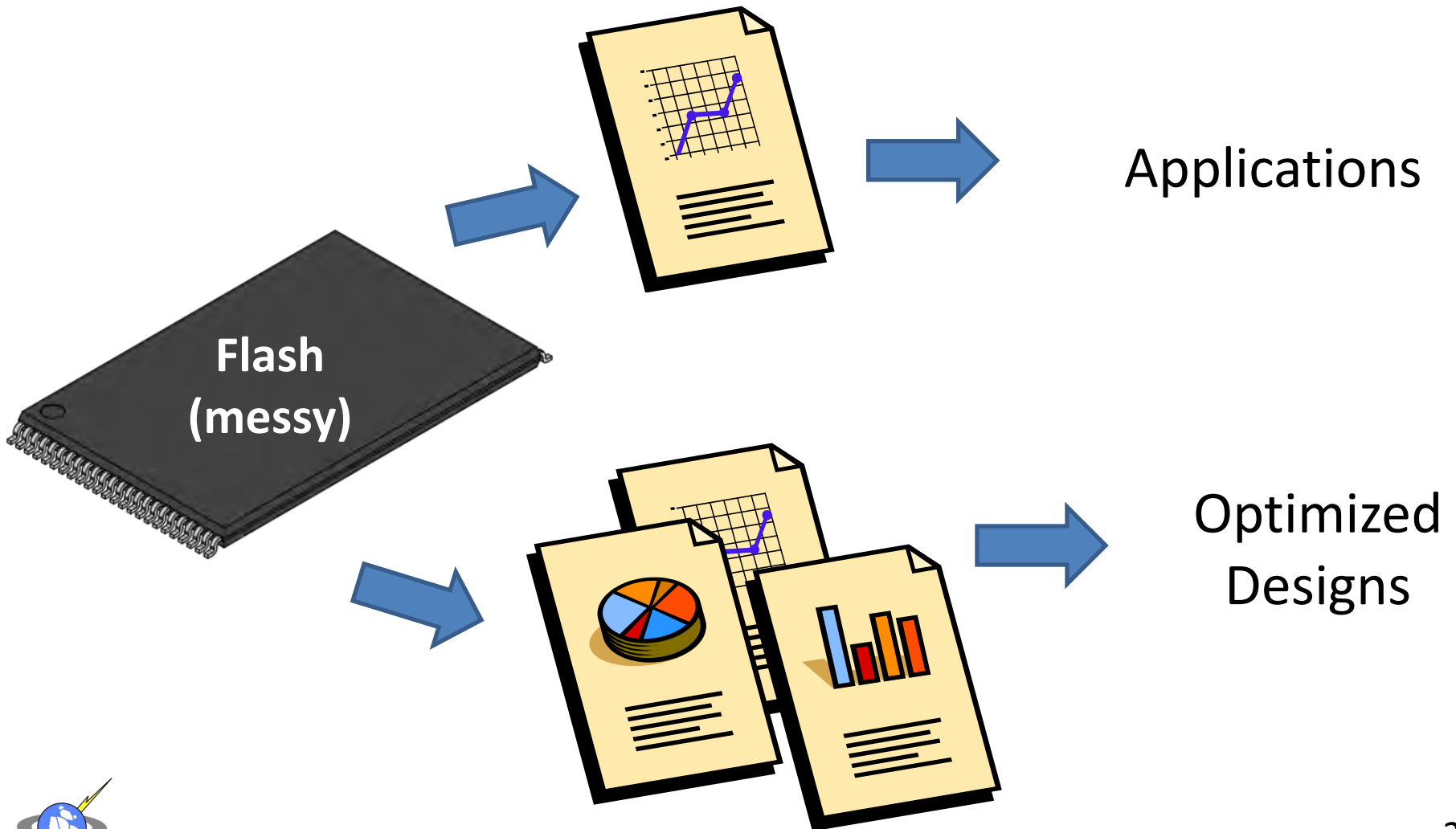

# Test Setup

- Custom-Built Daughter Board
- Xilinx XUP Board
- Full-fledge Linux
- Kernel module

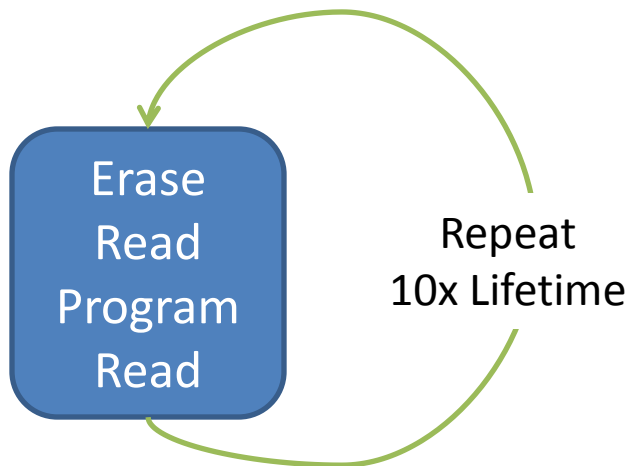
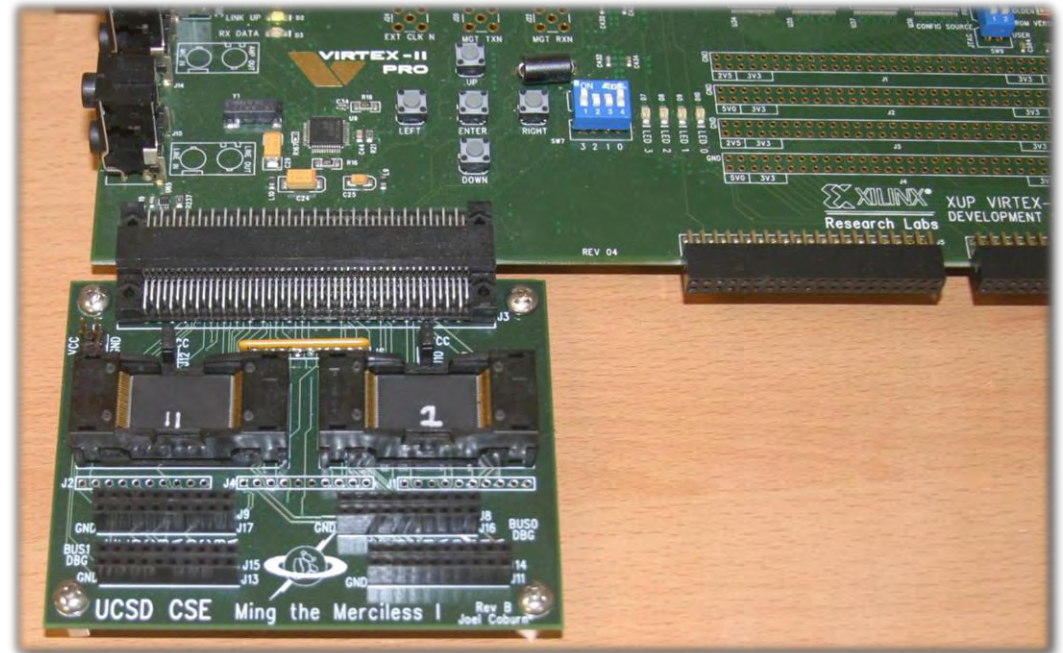



# The Test Subjects

Chip Name	Max PE Cycles	Tech Node	Capacity (Gb)	Bytes Page	Pages Block	Blocks Plane	Planes Die	Dies
B-MLC128-2	5,000	34nm	128	4096	256	2048	2	4
B-MLC32-2	5,000	34nm	32	4096	256	2048	2	1
B-MLC128	5,000	34nm	128	4096	128	4096	2	4
F-MLC16	5,000	41nm	16	4096	128	2048	2	1
C-MLC64	10,000	43nm	64	8192	128	4096	1	2
A-MLC16	10,000		16	4096	128	2048	2	1
B-MLC32	10,000	50nm	32	4096	128	2048	2	2
D-MLC32	10,000		32	4096	128	4096	1	2
B-MLC8	10,000	72nm	8	2048	128	4096	1	1
E-MLC8	10,000		8	4096	128	1024	1	2
B-SLC4	100,000	72nm	4	2048	64	2048	2	1

# Outline

---

- MLC Device Trends

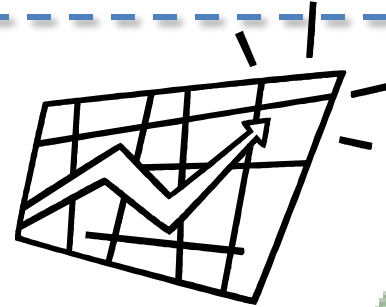

- Data Lifetime



- Benefits of Relaxation



- Modeling Flash

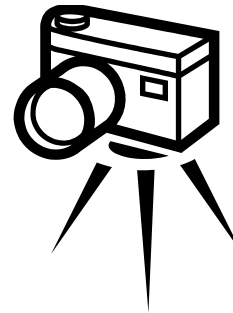

- New Application

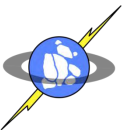

# Outline

---

- MLC Device Trends
- Data Lifetime
- Benefits of Relaxation
- Modeling Flash
- New Application

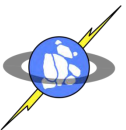

# Latencies

Decreasing Technology Node

### Read Latency ( $\mu$ s)

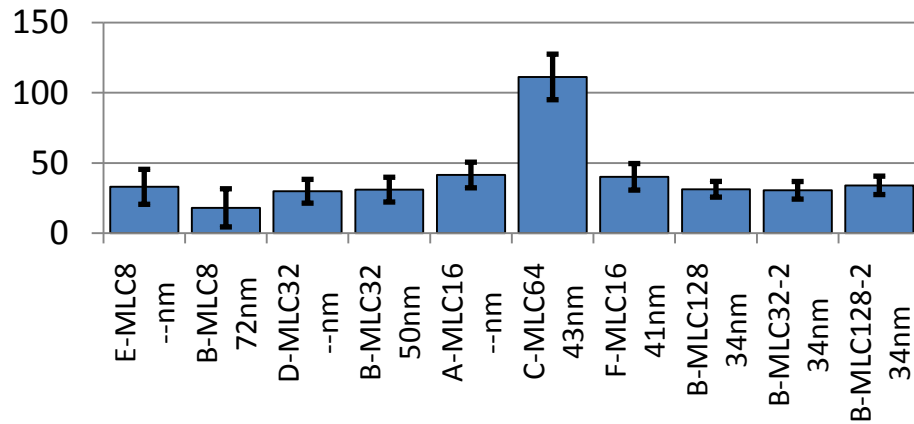

### Program Latency ( $\mu$ s)

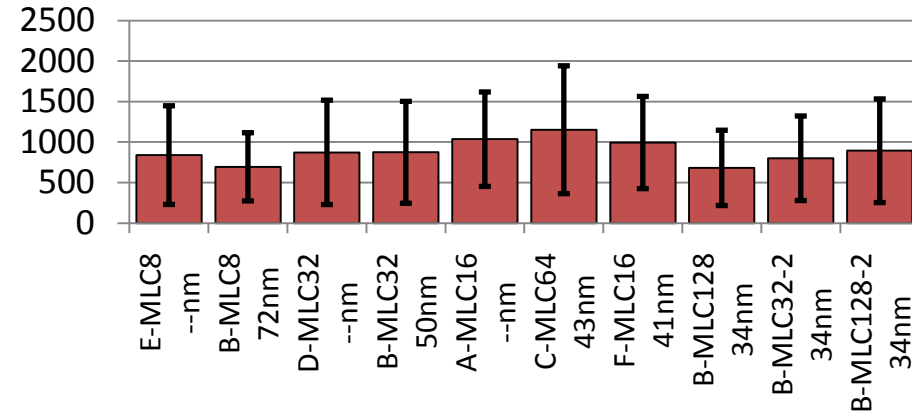

### Erase Latency (ms)

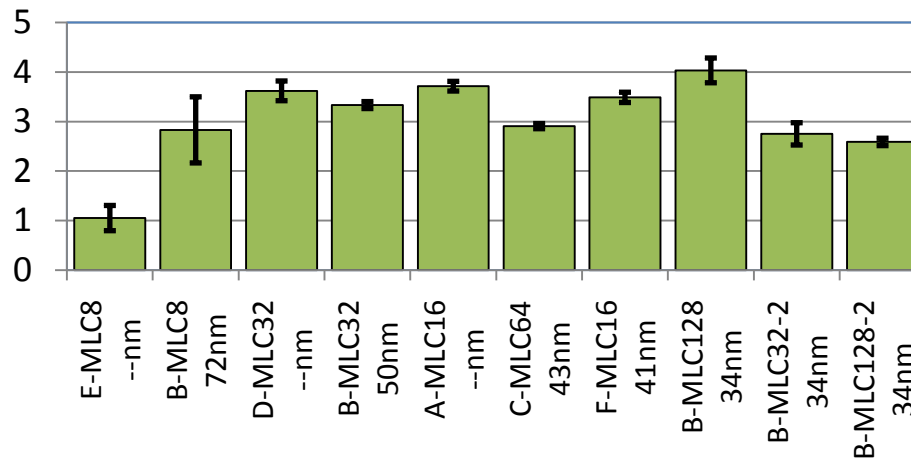

# BER over Cycles

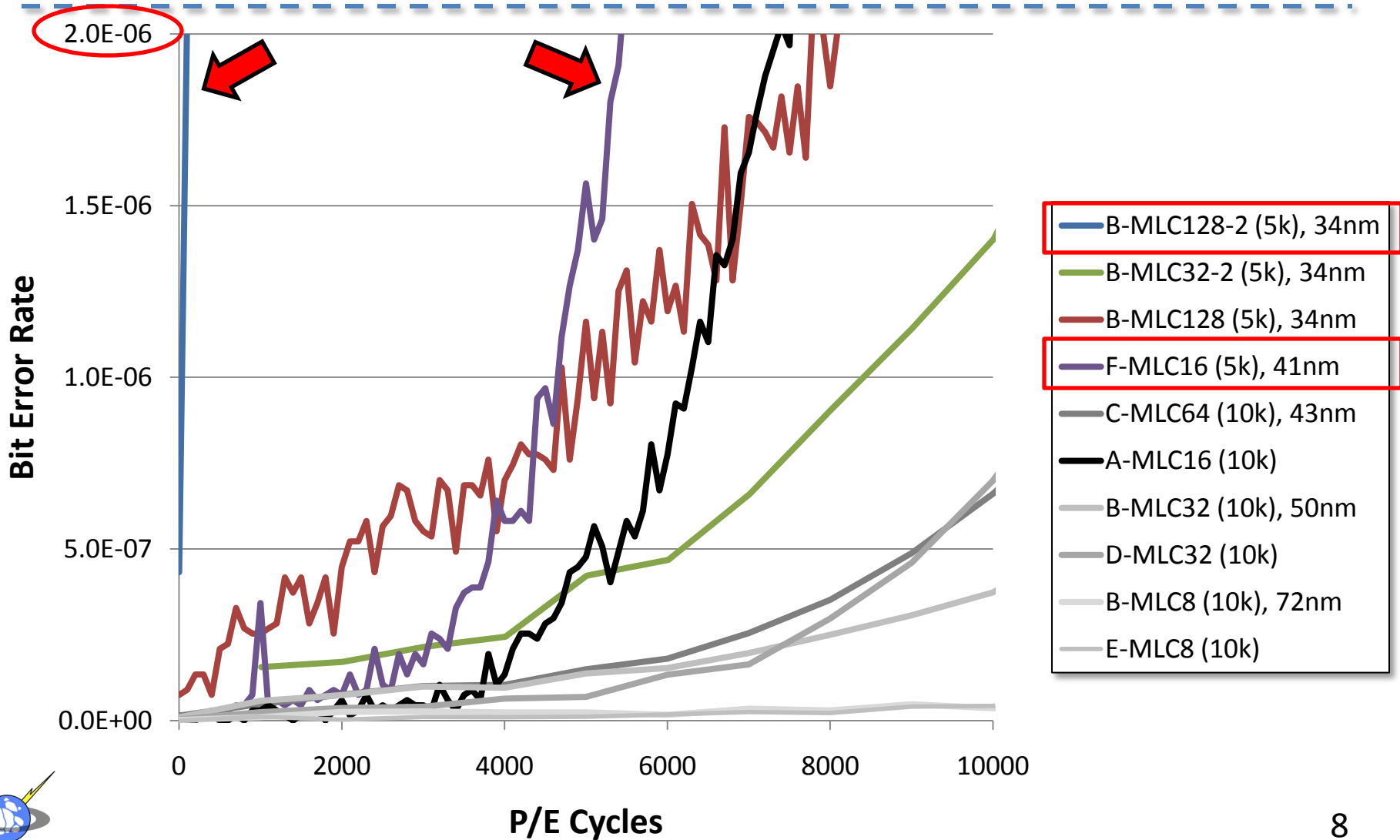



# BER over Cycles

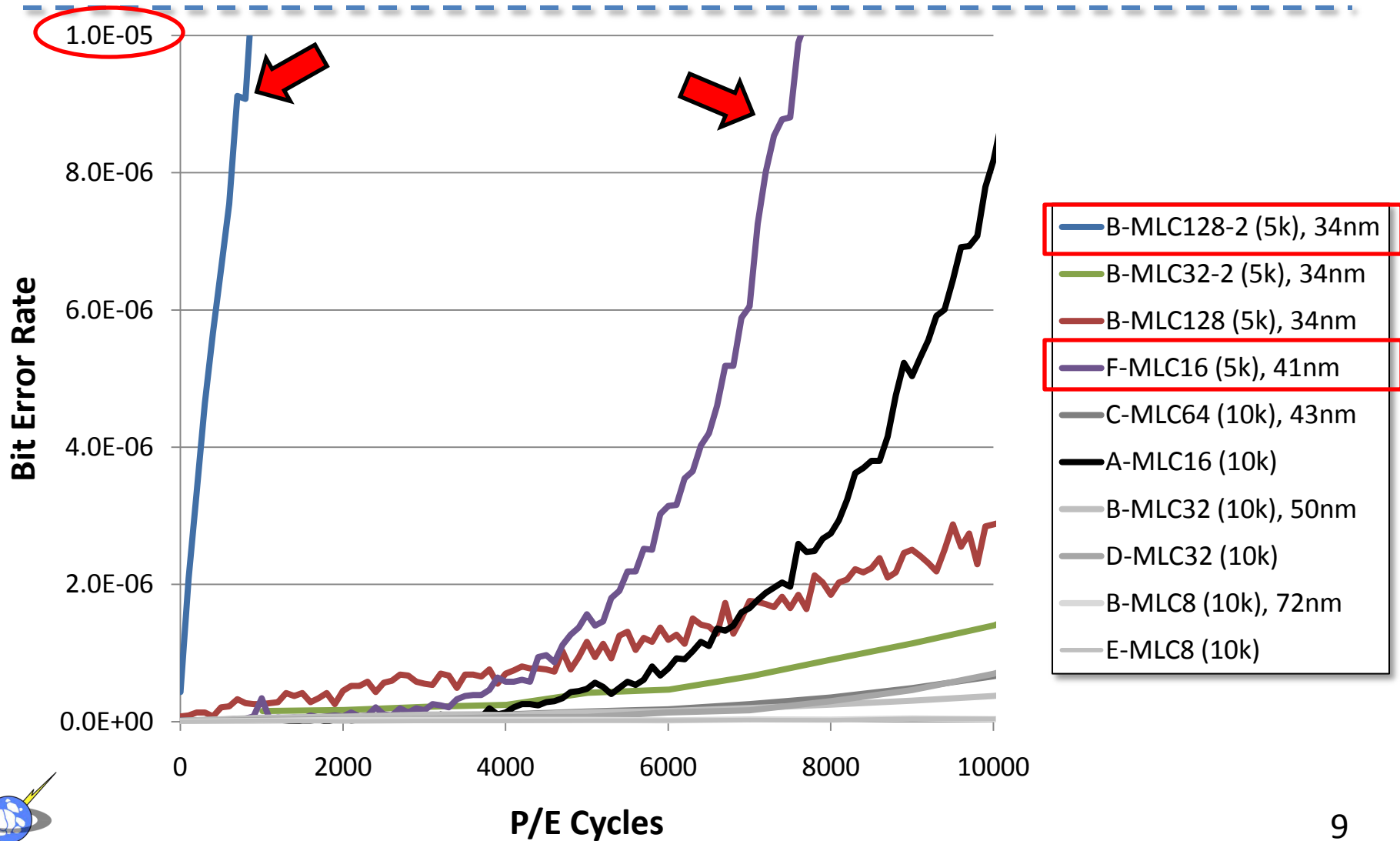

# Patterns in BER

F-MLC16

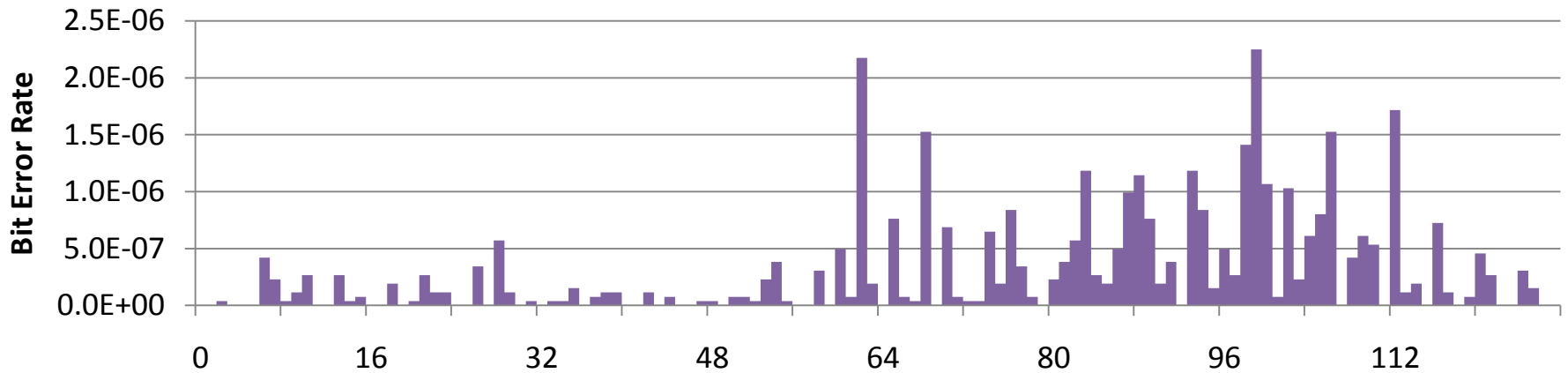

B-MLC32-2, 32nm

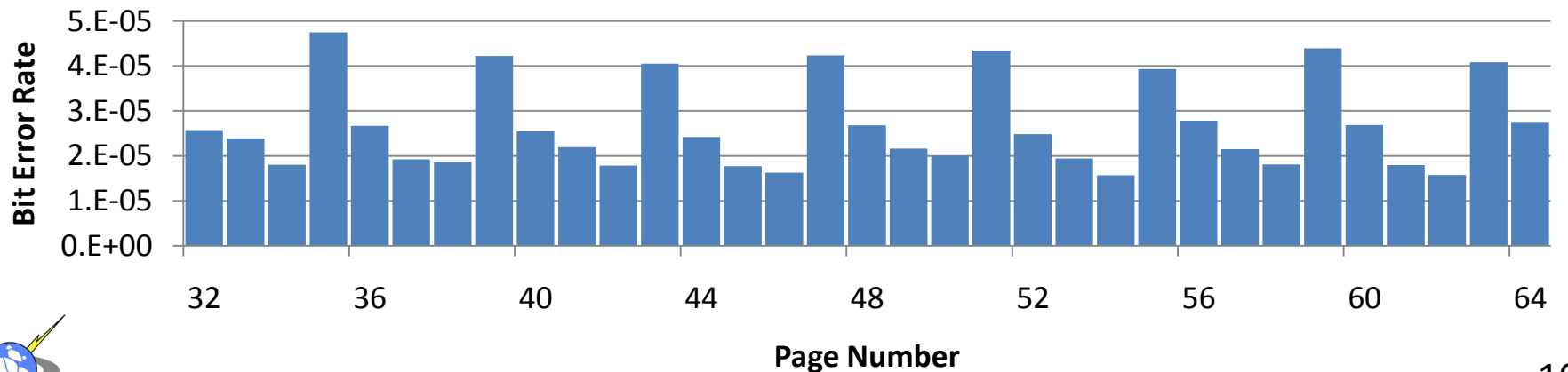

# Outline

---

- MLC Device Trends
- **Data Lifetime**
- Benefits of Relaxation
- Modeling Flash
- New Application

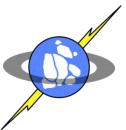
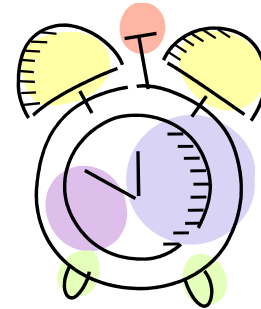

# Data Retention

---

How long does flash store data?

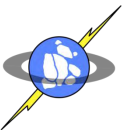
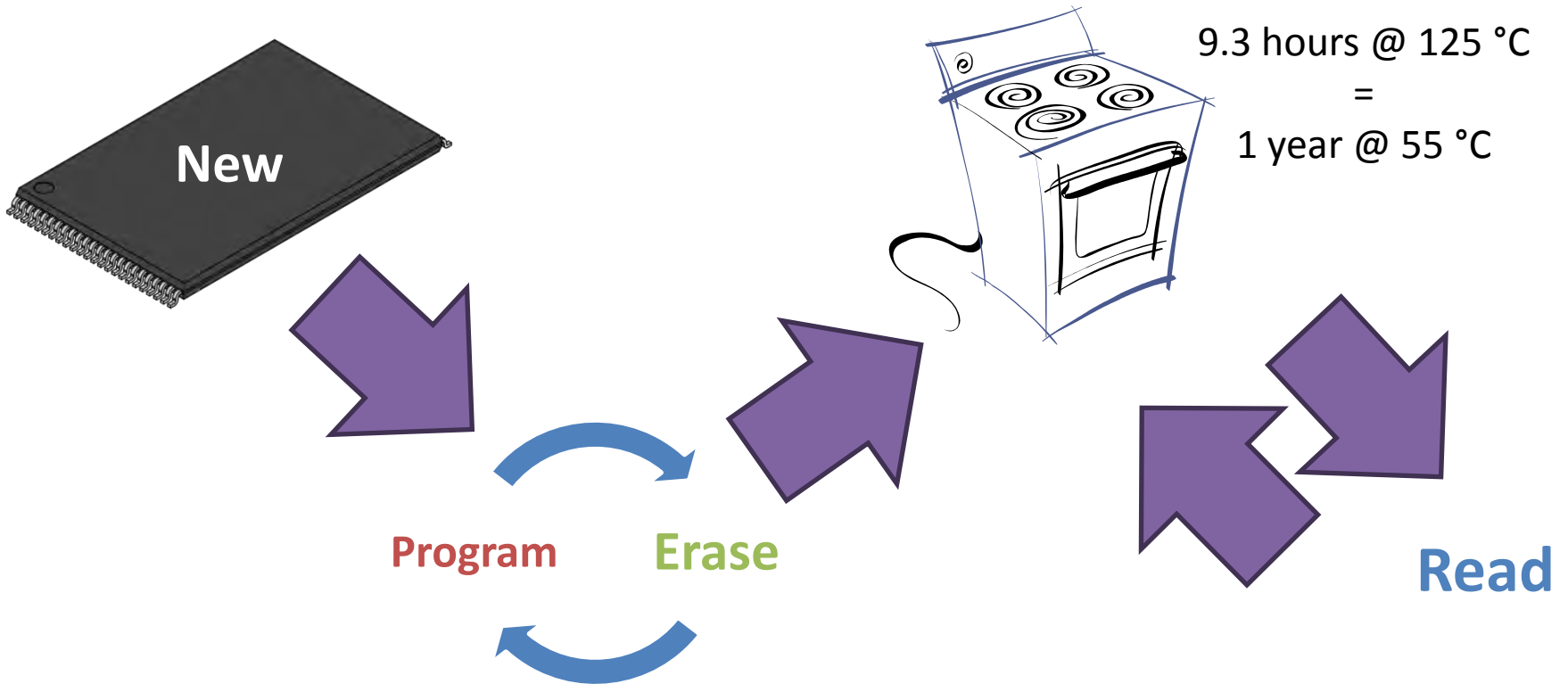

# Data Retention

- 400% of Max Cycles
- 200% of Max Cycles
- 100% of Max Cycles
- 50% of Max Cycles
- 25% of Max Cycles

### B-SLC4, 72nm

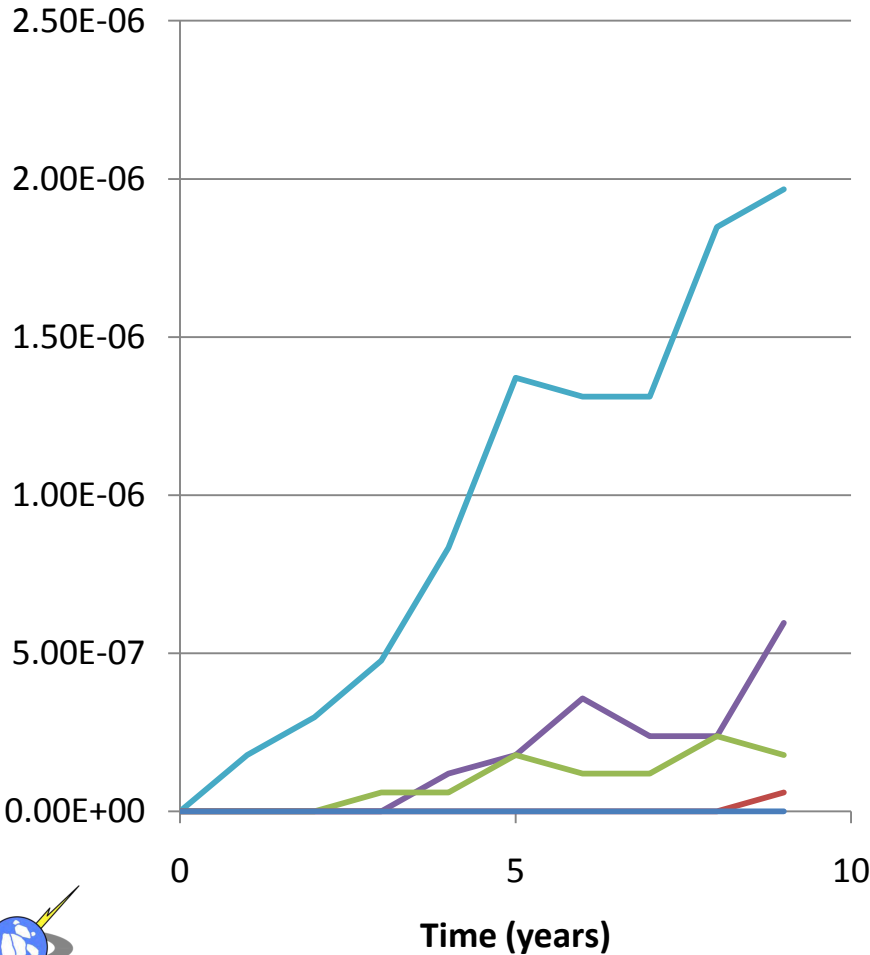

### B-MLC8, 72nm

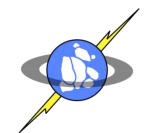
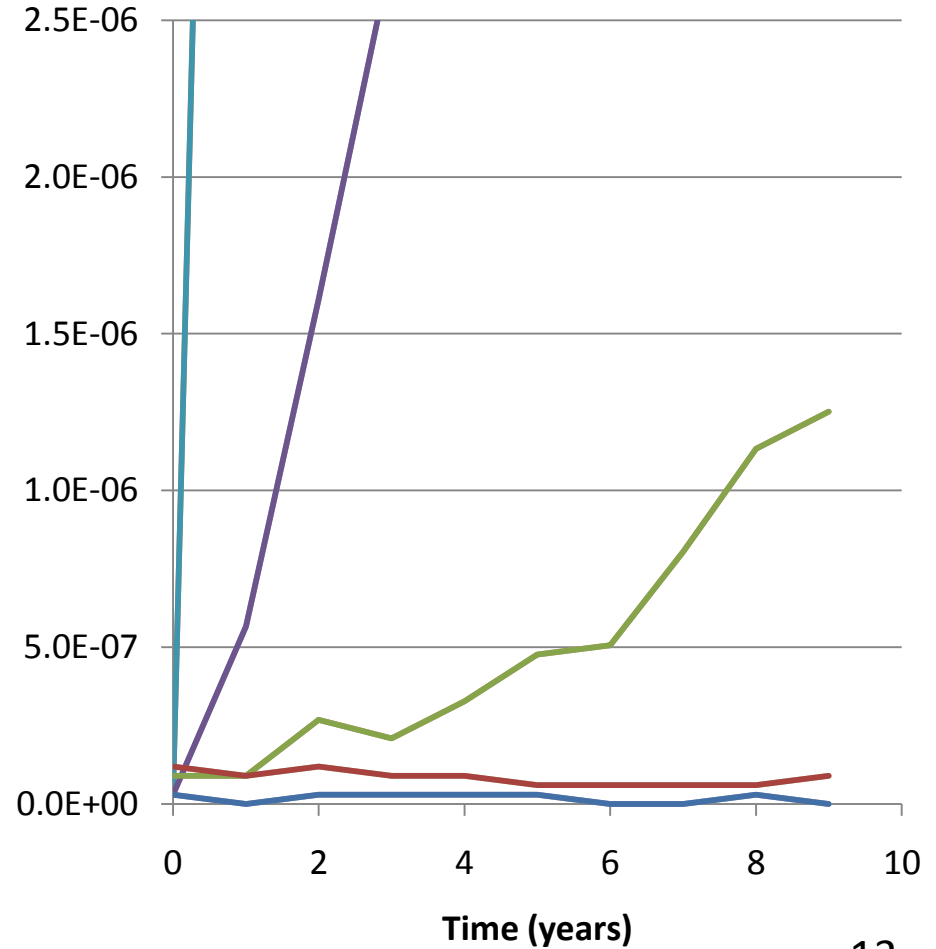

# Outline

---

- MLC Device Trends
- Data Lifetime
- **Benefits of Relaxation**
- Modeling Flash
- New Application

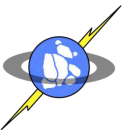

# Delay

---

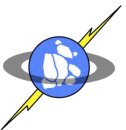
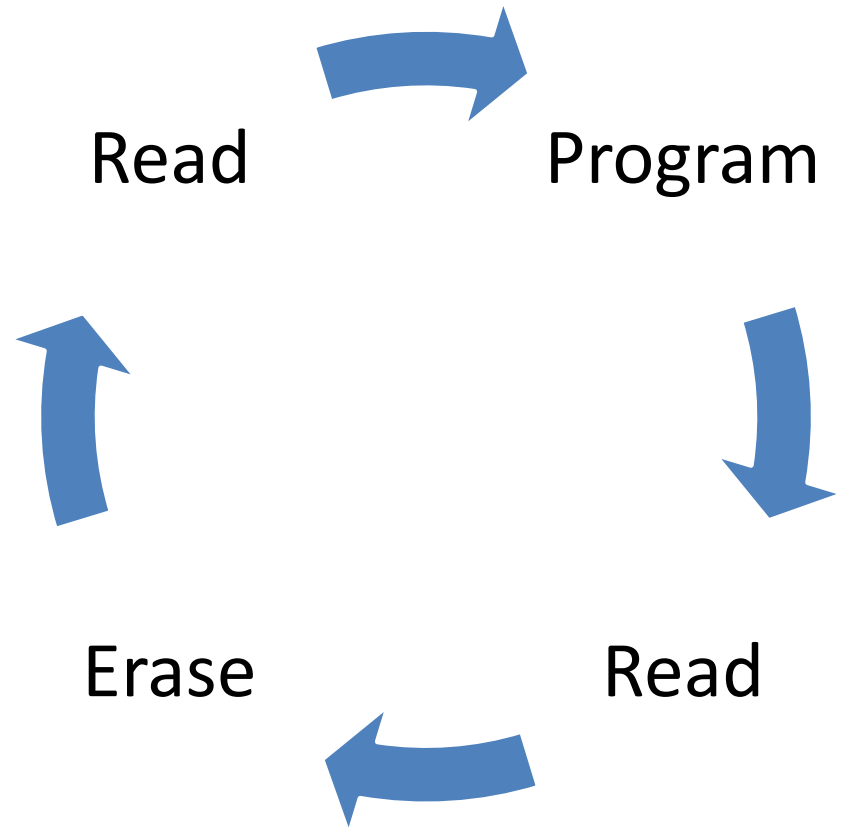
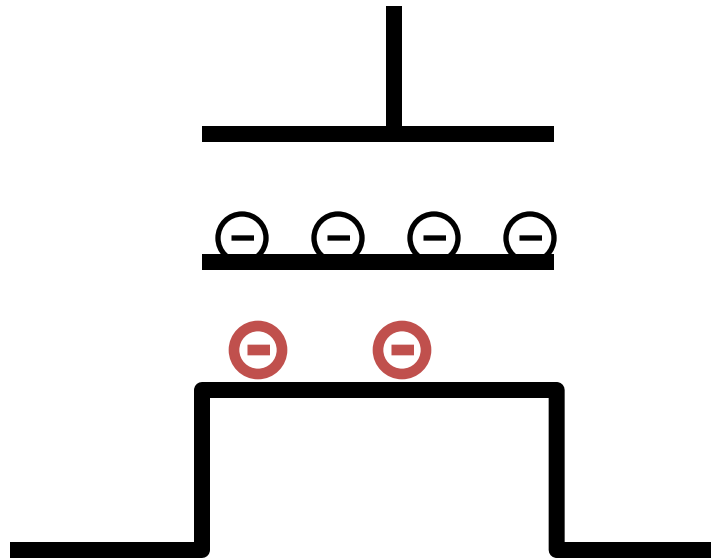

# Delay

---

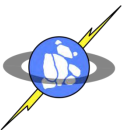
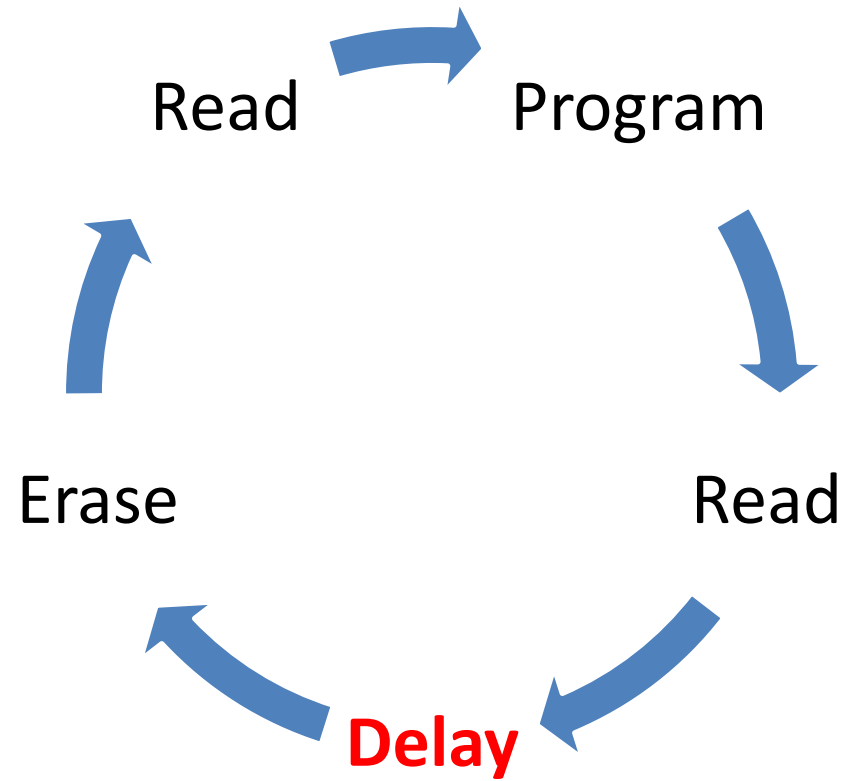
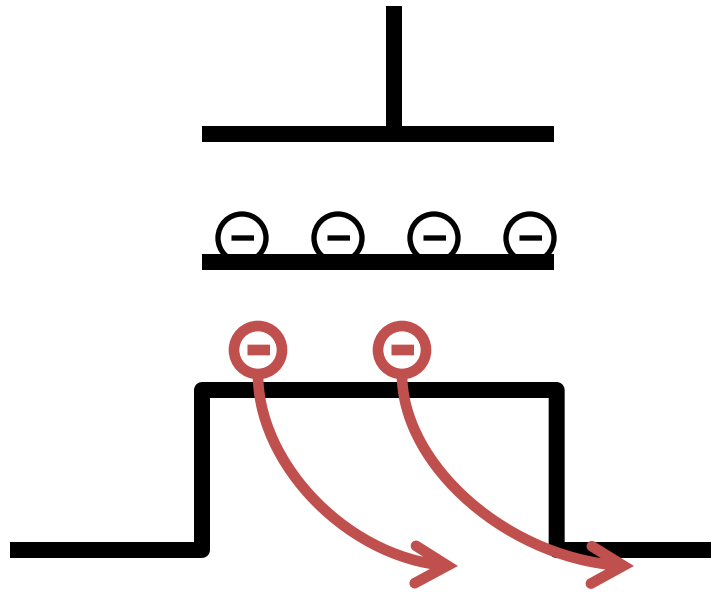



# Delay

## B-MLC32-2, 34nm

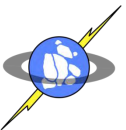
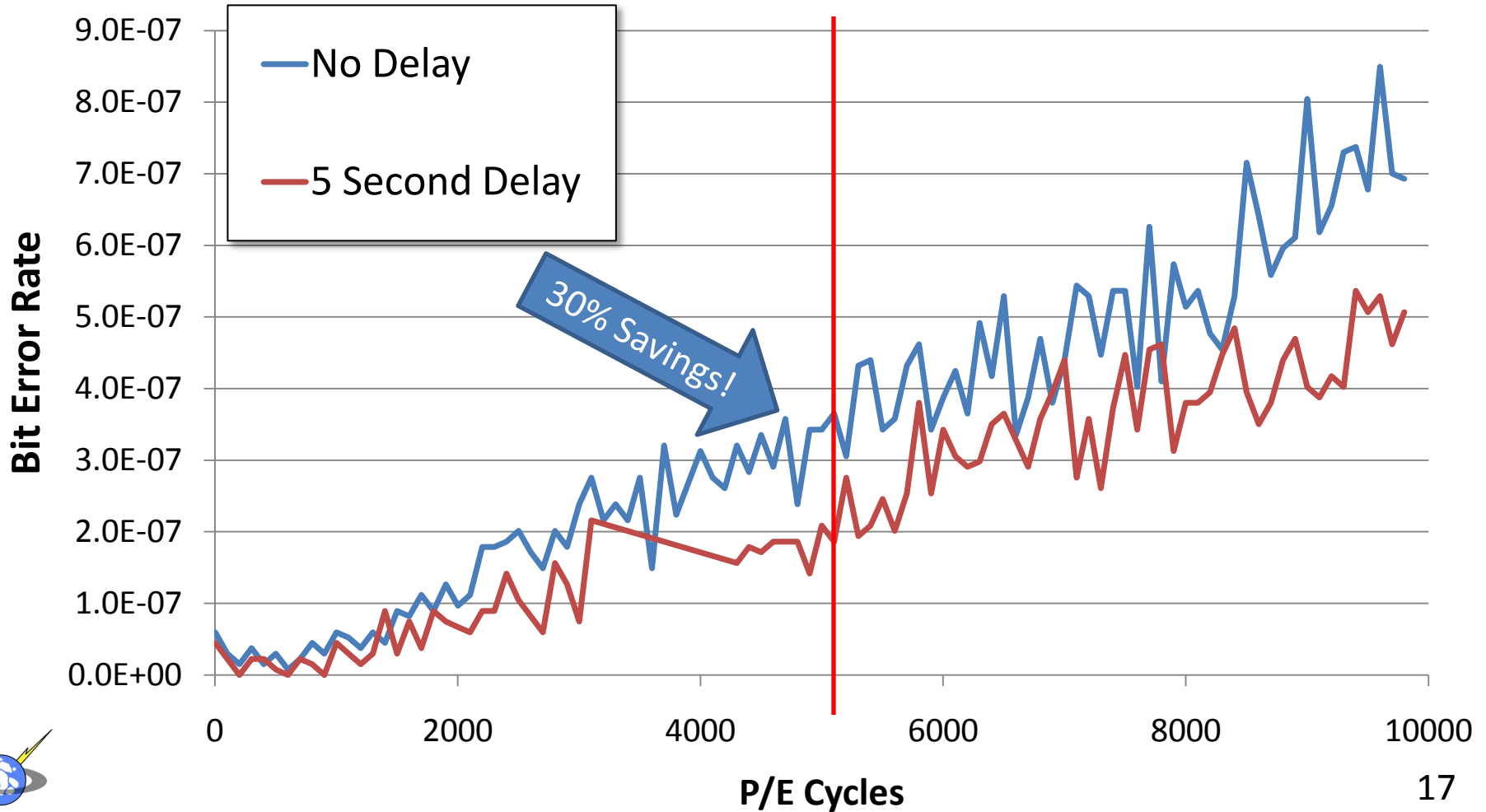

# Outline

---

- MLC Device Trends
- Data Lifetime
- Benefits of Relaxation
- **Modeling Flash**
- New Application

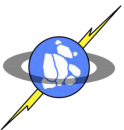
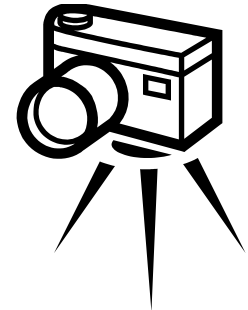

# Validation of Power Model

---

Flash Pages

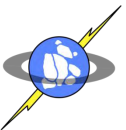
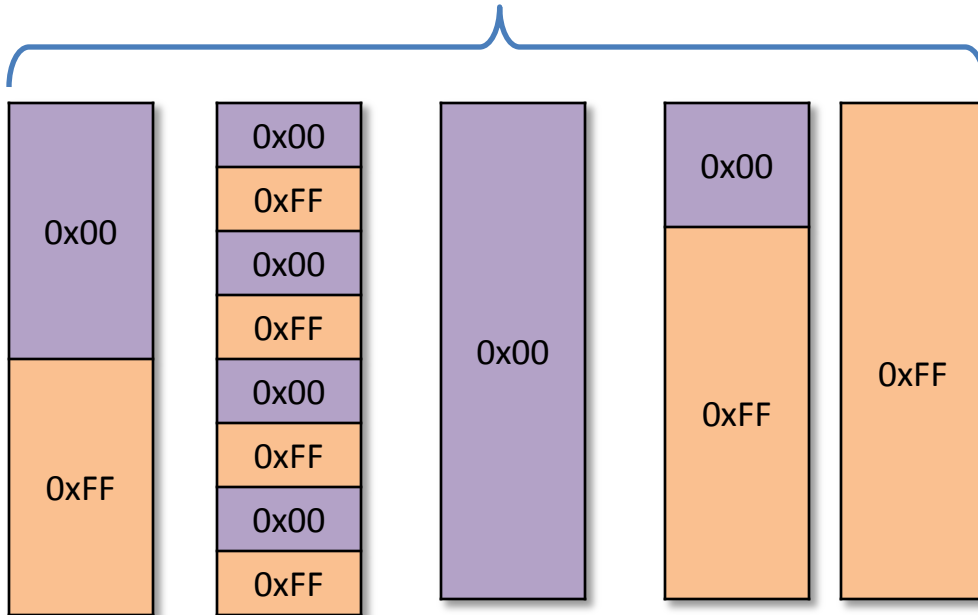

# Data Dependence - Transfer

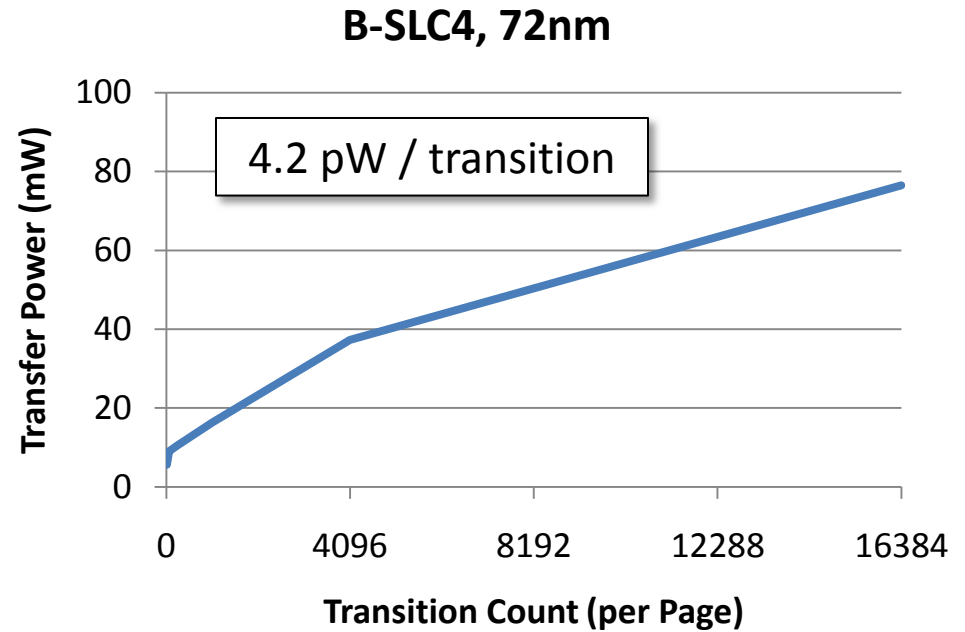
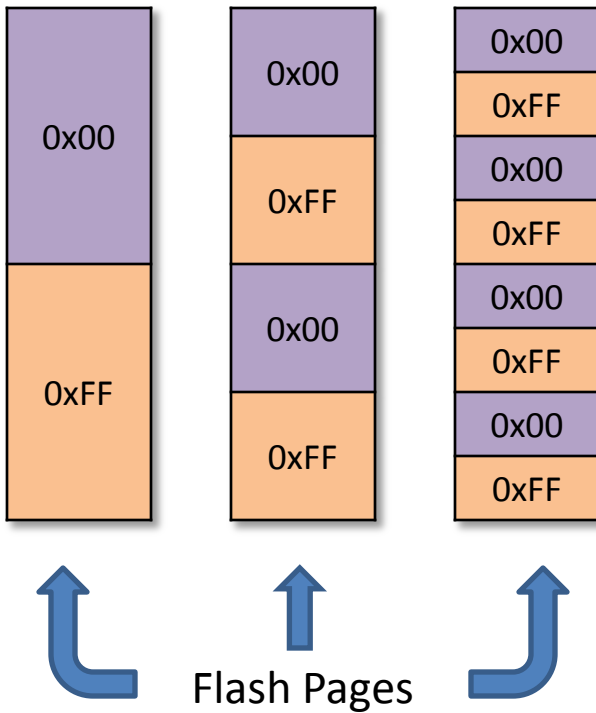

# Data Dependence - Cells

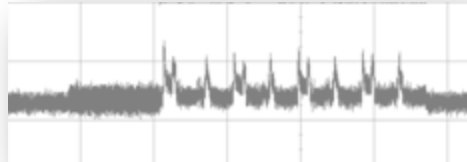
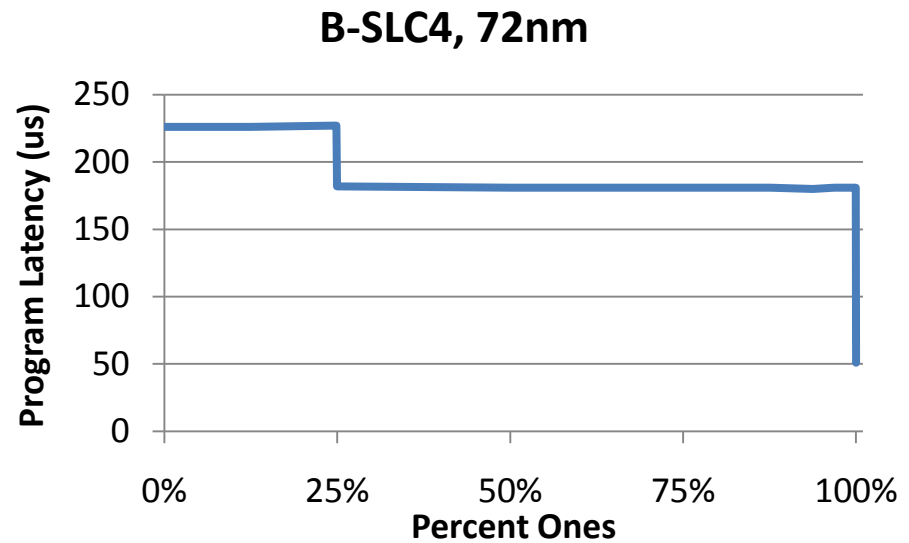
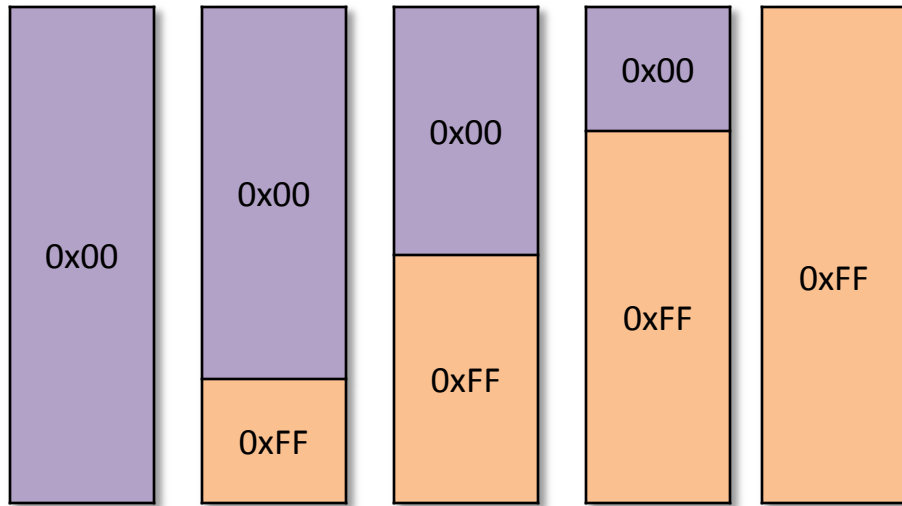

50% Ones

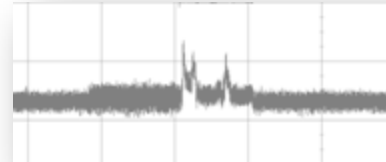

100% Ones

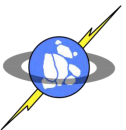

# Outline

---

- MLC Device Trends
- Data Lifetime
- Benefits of Relaxation
- Modeling Flash
- **New Application**

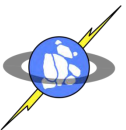

# Flash in Space

---



- Goals
  - Short-term: Earth-Orbiting Mission
  - Long-term: Space Flight Domination!
- Constraints
  - Low power
  - High Density
  - Limited ECC
  - High Radiation
- Advantages
  - Specified BERs
  - Full System Design

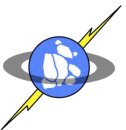

# Specialized Storage

---

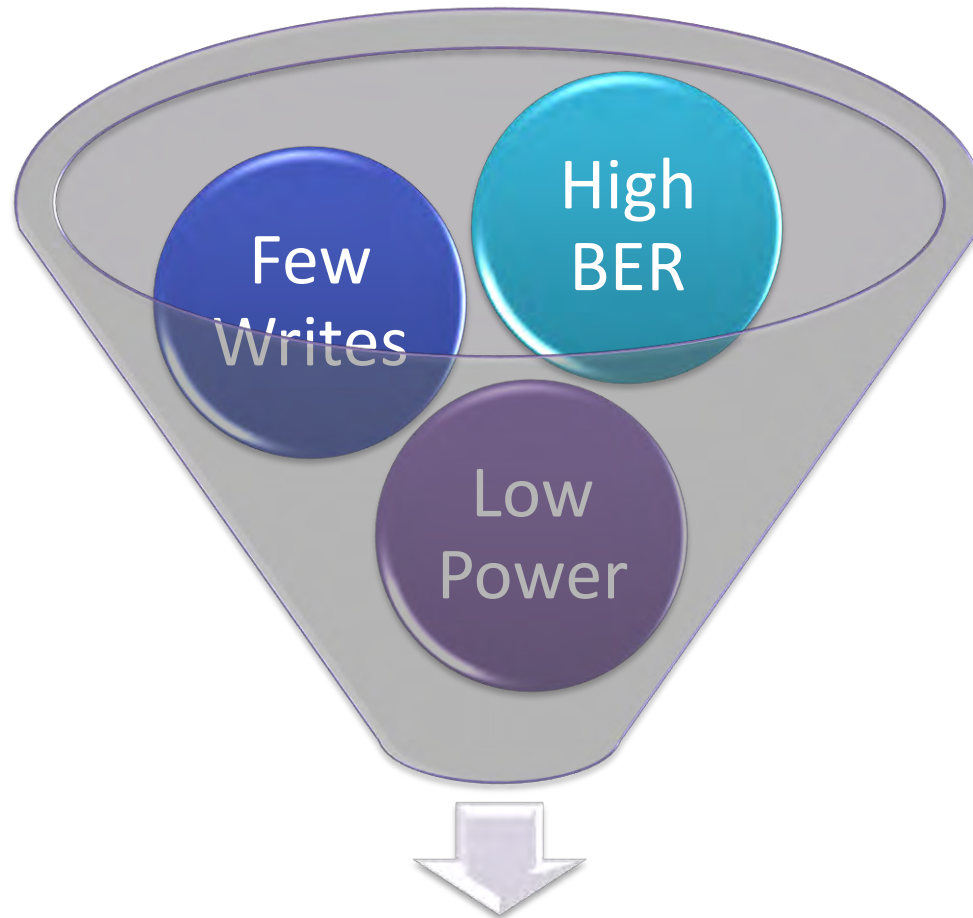

Personalized SSD

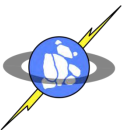



# Conclusion

---

- MLC Trends: Sophisticated ECC

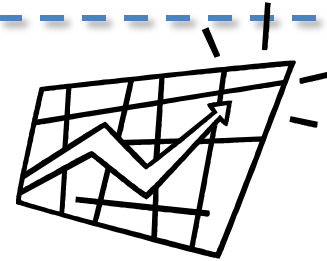

- Data's Shelf Life: Cycling Matters

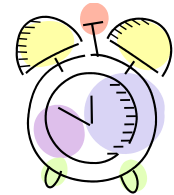

- Low Overhead ECC: Delay



- Rapid Development: Flash Model

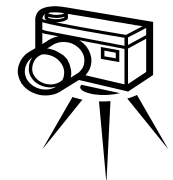

- Well Specified: Well Optimized

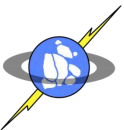

# Thank You

---

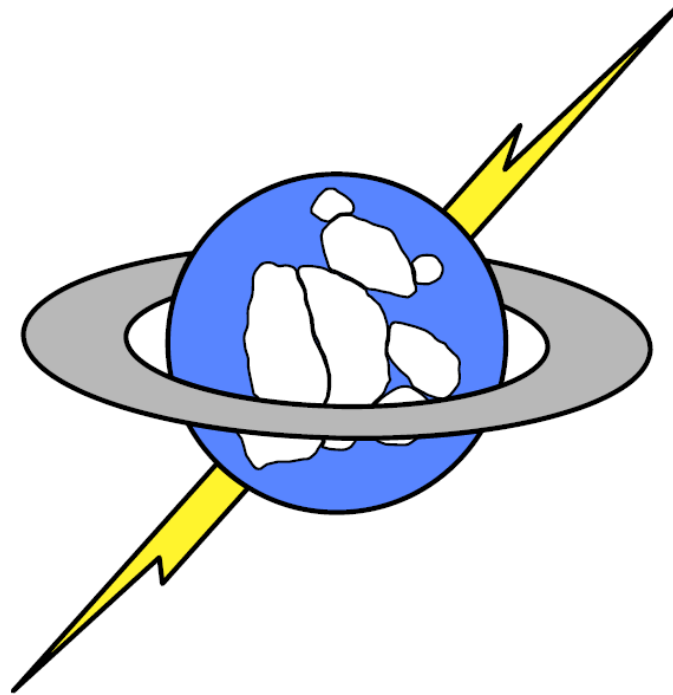

Non-volatile Systems Laboratory

